

7. Set $i_p=0$, $i_0=6.5$. Solve the equations for $v = -61$, $m = 0$, $h = 0.45$, $n = .4$. What happens? Try the same thing with $v = -45$. What happens? What does this tell you about the number of stable states for the membrane?

4.1 Numerical solutions and exercises

The `xpp` file has the following format:

```
# hhh.ode
init v=-65 m=0.05 h=0.6 n=0.317
par vna=50 vk=-77 vl=-54.4 gna=120 gk=36 gl=0.3 c=1 phi=1 i0=0
par ip=0 pon=50 poff=150
is(t)=ip*heav(t-pon)*heav(poff-t)
am(v)=phi*.1*(v+40)/(1-exp(-(v+40)/10))
bm(v)=phi*4*exp(-(v+65)/18)
ah(v)=phi*.07*exp(-(v+65)/20)
bh(v)=phi*1/(1+exp(-(v+35)/10))
an(v)=phi*.01*(v+55)/(1-exp(-(v+55)/10))
bn(v)=phi*.125*exp(-(v+65)/80)
v'=(I0+is(t) - gna*h*(v-vna)*m^3-gk*(v-vk)*n^4-gl*(v-vl))/c
m'=am(v)*(1-m)-bm(v)*m
h'=ah(v)*(1-h)-bh(v)*h
n'=an(v)*(1-n)-bn(v)*n
# track the currents
aux ina=gna*(v-vna)*h*m^3
aux ik=gk*(v-vk)*n^4
aux il=gl*(v-vl)
# track the stimulus
aux stim=is(t)
done
```

Note that I have set ϕ to 1 and thus have assumed the standard temperature of 6.3°C . I have also kept track of the currents and the stimulus.

We can use this file to explore the dynamics of the HH model as various parameters are changed. The most obvious parameter to vary is the applied current. By setting `I0` we can inject a constant current and by setting `IP` a pulse of current can be injected at `PON` lasting until `POFF`. In class I will play around a bit but I want you to do the following experiments. Use the Runge-Kutta integrator with a time-step of 0.05 and set `nOut` to 10 so that output occurs every half a millisecond. Also set the total amount of time to 200 msec and set the `Bounds` to 10000 so that the various currents do not exceed them.

1. With $I_0 = 0$ try to find the threshold by setting all the variables at rest but incrementing V by different amounts.
2. Change the current I_0 until the neuron fires repetitively. What is the critical value of current that you found?
3. With $I_0 = 10$ integrate the equations. In the **Data Browser** add a column called `minf` which contains the formula, $\text{am}(v)/(\text{am}(v)+\text{bm}(v))$. Compare this to the value of $m(t)$ by plotting the two during a few spikes. The two are almost identical. This tells you that it may be possible to approximate the dynamics of m by $m_\infty(V)$ thus making the differential equation one fewer variable.
4. Next, plot a phase-plane of n and h . They seem to lie along a line. What is the equation for this line? This says that n and h may be linearly related. This means that we may be able to reduce this 4 dimensional system to 2 dimensions by eliminating m and one of n, h .
5. Set $I_0 = 0$ and let the membrane start at rest. Set `Pon=0`, `poff=50`, `ip=-5`. This hyperpolarizes the membrane. What happens after the stimulus is removed? You should get a spike. Explain why this happens. (Hint: Look at the variable `h` during the hyperpolarization.)
6. Repeat the above experiment but use less negative values of `ip` is there a critical value below which you get no rebound spike?

Since currents are in nanofarads, let's see what the conversion factors are for the influx of calcium. Recall that a farad is a coulomb per second. The Faraday constant, F has units of coulombs per mole. Concentration is moles per liter, so that we need to know the volume in which the calcium is relevant. Volume is area times depth, so if we take a depth of 100 nM under our spherical cell, we can figure out the volume. Thus, with a linear uptake in calcium, the calcium concentration is satisfies:

$$\frac{d[Ca_i]}{dt} = -kI_{Ca}/(d \cdot A) - \beta[Ca_i]$$

where $k = 5.18 \times 10^{-3}$ to convert current (nanoamperes), time (milliseconds) and volume (cubic microns) to concentration in moles/liter. (To see this, note

$$\begin{aligned} 1 \text{ nA} &= 1 \times 10^{-12} \text{ Coulomb/msec} \\ 1 \text{ liter} &= 1 \times 10^{15} \mu^3 \end{aligned}$$

Thus

$$\frac{1 \times 10^{-12} \text{ Coulombs/msec}}{2 \times 96485 \text{ Coulombs/mole} \times 1 \times 10^{-15} \text{ liters}/\mu^3} = 5.18 \times 10^{-3} \text{ moles/liter/msec}$$

)

4 Exploring the Hodgkin Huxley equations

These famous equations model the squid-axon and are an excellent example of the type of model that one obtains by using the methods of the previous section. The equations are:

$$\begin{aligned} C \frac{dV}{dt} &= I(t) - \bar{g}_{Na} m^3 h (V - V_{Na}) - \bar{g}_K n^4 (V - V_K) - g_l (V - V_l) \\ \frac{dm}{dt} &= \alpha_m(V) - (\alpha_m(V) + \beta_m(V))m \\ \frac{dh}{dt} &= \alpha_h(V) - (\alpha_h(V) + \beta_h(V))h \\ \frac{dn}{dt} &= \alpha_n(V) - (\alpha_n(V) + \beta_n(V))n \end{aligned}$$

where

$$\begin{aligned} \alpha_m(V) &= \phi(.1(V + 40)/(1 - \exp(-.1(V + 40)))) \\ \beta_m(V) &= \phi(4.0 \exp(-(V + 65)/18)) \\ \alpha_h(V) &= \phi(.07 \exp(-(V + 65)/20)) \\ \beta_h(V) &= \phi(1/(\exp(-.1(V + 35)) + 1)) \\ \beta_n(V) &= \phi.125 \exp(-(V + 65)/80.) \\ \alpha_n(V) &= \phi(V + 55)/(1 - \exp(.1(V + 55))) \end{aligned}$$

and

$$\phi = 3^{(T-6.3)/10}$$

corrects for the temperature on the kinetics. The figures below illustrate the kinetic functions and the functions for m_∞ , τ_m , etc. Note that in all cases the steady state voltage dependence is sigmoidal with n and m monotonically increasing and h decreasing. Also notice that the maximum of the time constant of the sodium activation is about .5 and that of h and n are 8 and 5 respectively. The sodium activation is more than ten times as fast as the inactivation and the delayed rectifier current. Also note that at the activation threshold, the h is nearly zero.

as is usual. Then in the above, it is clear that $V = E_{Ca}$ makes the current vanish so that the “reversal potential” is indeed the Nernst equilibrium for calcium and linearizing about this reversal potential, we get the slope

$$\bar{g}_{Ca} = \frac{2P_{Ca}F^3E_{Ca}[Ca]_{out}/(RT)^2}{[Ca]_{out}/[Ca]_{in} - 1}$$

which if you check has dimensions of conductance per unit area. Thus, we can approximate (5) by

$$I_{Ca} = \bar{g}_{Ca}(V - E_{Ca})$$

where E_{Ca} is the Nernst equilibrium potential. We will use the two interchangeably, but keep in mind that the constant field equation is more correct.

3.1 Intracellular Calcium dynamics

The calcium dynamics are usually modeled in the following simple fashion.

$$\frac{d[Ca]_{in}}{dt} = -\frac{k}{2Fd}I_{Ca} - \frac{K_T[Ca]_{in}}{[Ca]_{in} + K_d} \quad (6)$$

or with just a linear term. Here F is the Faraday constant, d is the depth of the shell between the membrane (usually, e.g., 0.1μ), $k = 0.1$ for I in $\mu A/cm^2$, $[Ca]$ in millimolar, $K_T = 10^{-4}mM/ms$ and $K_d = 10^{-4}mM$. Note that as the calcium current increases in an inward direction, $-I_{Ca}$ becomes positive and thus intracellular calcium increases. The uptake of calcium is modeled here as a Michaelis-Menten type reaction. An even simpler uptake would be simply linear. These constants are for thalamic neurons but are in the right ballpark for most models. Finally, in general, extracellular calcium is about 2 mM and intracellular tends to be around 2.410^{-4} mM.

3.2 Calcium dependent potassium

Since this is responsible for adaptation and for many types of bursting dynamics, I want to describe the calcium dependent potassium. There are a number of models for this. The simplest are of the form:

$$I_{K(Ca)} = \bar{g}m^p(V - E_K)$$

where

$$\frac{dm}{dt} = \alpha_m([Ca])(1 - m) - \beta m$$

and

$$\alpha_m([Ca]) = \alpha[Ca]_{in}^n.$$

McCormick et al use $n = 2$ and $\alpha = 48ms^{-1}/mM^2$ and $\beta = 0.03ms^{-1}$.

I will make a very general model which incorporates most of the currents that are of interest.

3.3 Units - Again!

Many modelers define the conductances, etc in absolute terms, such as a capacitance of, say, 0.29 nF. Most of the time, I will define my units in terms of “size per unit area,” but some of the models I describe (in particular, the big cortical mix and match model) will be in absolute numbers. A modeler who does that is making an implicit assumption about the size of the cell. For example, in the above capacitance example, if I assume a capacitance value of $1\mu F/cm^2$ then $0.29nF$ corresponds to a cell with a total membrane area of $29000\mu m^2$. Given that typical conductances are in units of mS/cm^2 then typical absolute conductances would be of the order of microsiemens, currents are in nanoamps, capacitance in nanofarads. In McCormick’s and Huguenard’s model (J. Neurophys 68:1373, 1384) sodium has a conductance of $12\mu S$ for the $29000\mu^2$ cell which translates into $41mS/cm^2$. (Make sure you can do this calculation – keep in mind that $1\mu^2 = 1 \times 10^{-8}cm^2$.)

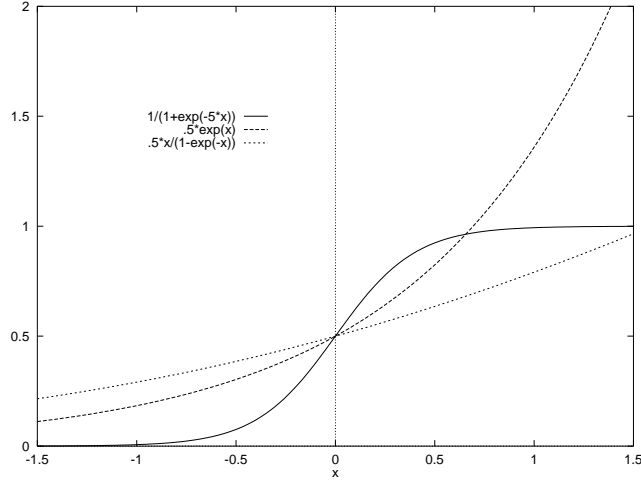

Figure 3: The three different functional forms for the gating rates. Only the increasing ones are shown; decreasing ones are just mirror images. All are chosen to pass through 0.5 at 0.

2. Linear-Exponential:

$$\alpha(v) = C_1(V - V_T)/(1 - e^{(V-V_T)/V_s})$$

3. Logistic:

$$\alpha(v) = C_1/(1 + e^{-(V-V_T)/V_s})$$

All three are defined by 3 parameters, the magnitude, C_1 , the “threshold”, V_T and the slope at threshold, V_s .

3 Calcium dynamics and I_{K-AHP}

Most of the models that are commonly used treat the current as in (4) but we will see that calcium is somewhat special and requires a more complex approach.

Intracellular calcium is heavily buffered so that the concentration tends to be very low. As a consequence the reversal potential for calcium can not really be modeled as a fixed value. The intracellular calcium levels are on the order of 1000 times lower than extracellular calcium which accounts for the rather large reversal potential for calcium. The way that many researchers model calcium is through the *constant field equation*

$$I_{Ca} = P_{Ca} m^p h^q \frac{4F^2}{RT} V \left(\frac{[Ca]_{in} e^{2VF/RT} - [Ca]_{out}}{e^{2VF/RT} - 1} \right) \quad (5)$$

where $F = 96480$ Colombs/mole, $R = 8.3145 J/mol - ^\circ K$, P_{Ca} is the permeability, and T is the temperature in degrees Kelvin (centigrade plus 273).

NOTES:

- 1 V = 1 joule/ Coulomb
- Permeability is measured in cm/sec and concentration is in moles/liter or moles/cubic centimeter. Thus, the dimensions above are coulombs/(sec-square centimeter) which is just current per unit area.

To get some intuition behind this expression, define

$$E_{Ca} = \frac{RT}{2F} \ln \frac{[Ca]_{out}}{[Ca]_{in}}$$

By using a series of different initial voltages and voltage jumps, we can first find the best power, p to fit the data. Then we can find the maximal value of the conductance. Finally, we can use the above formula to fit the conductance to a series of exponential curves and use these to find $n_\infty(V)$ and $\tau_n(V)$ for each value of the voltage. For gates that have both activation and inactivation, the voltage clamp is a little trickier, but not all that bad. With the advent of channel blockers, it is now a fairly standard (though by no means easy!) experimental protocol. A paper illustrating the technique applied to a calcium current in the thalamus is Coulter et al J. Physiol. London, 414:587-604.

2.2 Some common currents in cortical and thalamic neurons

There are many different currents in the cortex and thalamus. I only touch on a few of them.

name	ion	type	speed	Rev. Pot	threshold
I_{Na} Fast Sodium	[Na]	act/inact	very fast	45 mV	-50 mV
I_{Nap} Persistent Sodium	[Na]	act/inact(slow)	fast	45 mV	-65 mV
I_K Delayed rectifier	[K]	act	fast	-100 mV	-40 mV
I_A A-current	[K]	act/inact	fast	-100 mV	-60 mV
I_{AHP} Ca-dependent K	[K]	act (Ca-dep)	moderate-slow	-100 mV	-
I_M Slow potassium	[K]	act	slow	-100 mV	-35 mV
I_{K2} Slow potassium	[K]	act/inact	slow	-100 mV	-40 mV
I_T Transient Ca	[Ca]	act/inact	slow	150 mV	-60 mV
I_L High thresh. Ca	[Ca]	act	fast	150 mV	-10 mV
I_h Sag current	[Ca]&[Na]	inact	slow	0-40 mV	-
I_{leak} Leak	[Cl],[K], [Na]	passive	-	-60 mV	-

Given the above table and the form for the kinetic parameters, α, β one can easily put together models for active membranes. This can be regarded as a kind of mix and match affair which results in a huge variety of models. In spite of this, there are virtually no differences between the fundamental models of cardiac, smooth muscle, squid axon, thalamic relay cells, etc. Each can be written as (2) where the I_k each satisfy

$$I_k = \bar{g} m^p h^q (V - E) \quad (4)$$

and m, h satisfy equations like (3). In many cases, the calcium current is handled slightly different than the linear conductance model and instead, the constant field equation is used:

$$I_{Ca} = P m^p h^q \frac{(zFV)^2}{RT} \frac{[Ca_i] - [Ca_o]e^{-zFV/RT}}{1 - e^{-zFV/RT}}$$

Here instead of conductance, the permeability is used.

The best known examples of these models are the Hodgkin-Huxley equations which have 3 currents, (i) passive leak, (ii) fast sodium, and (iii) delayed rectifier.

All of the currents mentioned in the table above have been found in cortical or thalamic neurons. These currents are responsible for the intrinsic firing properties of neurons which include three different types: (i) regular spiking neurons (ii) fast spike neurons (iii) bursting neurons.

Recall that the typical channel gate satisfies

$$\frac{dx}{dt} = \alpha(V)(1 - x) - \beta(V)$$

The functions α, β are generally of three different forms (see Figure 3)

1. Exponential:

$$\alpha(v) = C_1 e^{(V - V_T)/V_s}$$

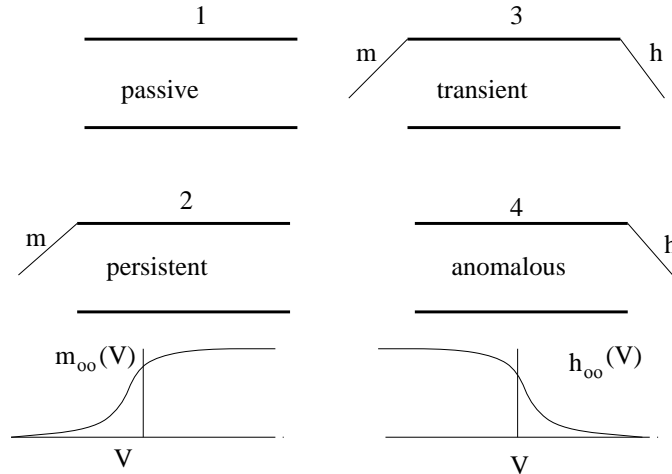

Figure 2: The four different types of gated channels. (1) The passive gate lets ions through a a rate proportional to the voltage drop, (2) The persistent gate requires the “m” activating gate to be open, (3) the transient gate requires both the activating gate and the inactivating gate to be open, (4) the anomalous requires the inactivating gate to be open. The functions m_∞ and h_∞ are shown in the figure

The key points to note in general are that (i) $m_\infty(V)$ is an **increasing** function of voltage for activating gates. That is, the higher the potential, the higher the probability of the activation gate being open. Figure 2 shows the typical activation function. (ii) Inactivation gates decrease with increased voltage and are generally slower than the activation gates. (iii) While the gates are generally dependent on voltage, some potassium gates depend on the intracellular calcium concentration or on other modulatory substances.

2.1 An aside on experimental issues: Voltage clamp

The equations for the gating variables are all well and good in theory, but in practice, how does one compute them? This is done by a technique known as the voltage clamp. One holds the voltage as a fixed value and then changes it by some incremental amount. The current that passes is then measured. Lets take, for example, the squid axon model of Hodgkin and Huxley. Suppose that we chemically block the sodium channel. (There are many different pharmacological agents that can be used to block different channels. Sodium is blocked by tetrodotoxin, TTX, found in the puffer fish. Tetraethylammonium , TEA, blocks certain kinds of potassium channels.) The the current passed is due solely to the leak, the capacitance, and the leak. Since the capacitative current is just a short pulse and is zero otherwise, we can ignore that. The current is thus:

$$I(t) = g_L(V - E_L) + g_K(t)(V - E_K)$$

We know the voltage and the reversal potentials, so we can solve for the time-dependent conductance:

$$g(t) = \frac{I(t) - g_L(V - E_L)}{V - E_K}.$$

Now, the idea is that the conductance should be of the form:

$$g(t) = g_{\bar{K}} n^p(t)$$

where

$$\frac{dn}{dt} = (n_\infty(V) - n)/\tau_n(V).$$

For a fixed value of voltage, this is just a linear differential equation which has a solution:

$$n(t) = n_\infty(V) + (n(t_0) - n_\infty(V))e^{-t/\tau_n(V)}.$$

one can measure the properties of the action potential by voltage clamp studies in order to understand the basic dynamics of active channels. The idea is really just an application of Ohms law and we can thus write:

$$C_m dV/dt = - \sum_k I_i \quad (2)$$

where I_i are just the different currents per unit area due to the channels. Each of these can be decomposed as:

$$I_i = \text{Conductance of open Channel} \times \\ \text{Density of channels} \times \\ \text{probability of channel open} \times \\ \text{electromotive driving force}$$

There are at least 4 different types of channels:

1. Passive

$$I_i = \bar{g}(V - \bar{E})$$

2. Persistent or noninactivating

$$I_i = \bar{g}m(t)^p (V - \bar{E})$$

3. Transient or inactivating

$$I_i = \bar{g}m(t)^p h(t)^q (V - \bar{E})$$

4. Anomalous or activated by hyperpolarization

$$I_i = \bar{g}h(t)^q (V - \bar{E})$$

where m, h are dynamic variables that are in $[0, 1]$ and are generally voltage dependent. m will generally increase as the voltage increases and h decreases as the voltage increases. The powers, p, q are meant to represent the components of a channel. For example, the potassium channel consists of 4 subunits and so the power is 4. The diagram in Figure 2 should make this clear.

In the squid axon, potassium is of type 2 (persistent noninactivating) and sodium is of type 3 (transient or inactivating.) In the thalamus, there is a type 3 calcium current that is very important for synchronizing spindle activity. Now lets examine the dynamics of the channel variables, m, h . The ideas are grounded in chemical kinetics and can be neatly summarized by the mass action model:

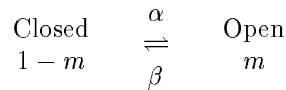

Using the law of mass action we get

$$\frac{dm}{dt} = \alpha(V)(1 - m) - \beta(V)m$$

which we can rearrange to the better known form:

$$\tau(V) \frac{dm}{dt} = m_\infty(V) - m \quad (3)$$

where

$$\tau(V) = \frac{1}{\alpha(V) + \beta(V)} \\ m_\infty(V) = \frac{\alpha}{\alpha + \beta}$$

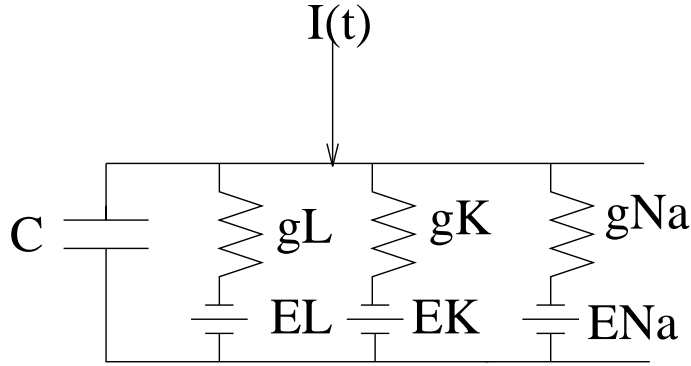

Figure 1: Equivalent circuit for Squid Axon

the permeabilities act like conductances and the equilibrium potentials act as batteries. Consider Figure 1 which ignores the pumps for sodium and potassium. Then the equations for the membrane are:

$$C \frac{dV}{dt} = g_{Na}(E_{Na} - V) + g_{Cl}(E_{Cl} - V) + g_K(E_K - V) + I \quad (1)$$

where I is the applied current. The membrane potential is defined as a steady state of (1) that is the right-hand side must vanish. This enables us to solve for V :

$$V_m = \frac{g_{Na}E_{Na} + g_K E_K + g_{Cl}E_{Cl} + I}{g_{Na} + g_K + g_{Cl}}$$

If $I = 0$, $g_{Cl} = 0$, $g_K = 10 \times 10^{-6} S$, $g_{Na} = .5 \times 10^{-6} S$ then $V_m = -69mV$.

Homework:

1. Compute the sodium and potassium currents at rest (Hint: The current of an ionic species is $I = g(E - V)$ where E is the reversal potential, g the conductance, and V the resting potential.)
2. What is the effect of g_{Cl} on the resting potential. That is if g_{Cl} is small and positive, will this raise or lower the potential.
3. Given that $E_{Ca} = 150mV$ suppose that $g_{Ca} = .2 \times 10^{-6} S$. What is V_m ?
4. Suppose that g_{Na} increases 500 fold as it does during the action potential. What is V_m in this case?
5. Again ignoring chloride and using the values in the example for the conductances of sodium and potassium, how much current must you inject to increase the potential by $10mV$?
6. Rewrite (1) as

$$C dV/dt = \bar{g}(V_m - V) + I$$

where \bar{g} is the effective conductance. Using the given values for the potassium and sodium conductances and noting that $C = C_m \times A$ where A is the area of the membrane and using $C_m = 1\mu F/cm^2$ what is the area of the membrane if the time constant is $1msec$. (Hint: The time constant is $C/\bar{g} = C_m A/\bar{g}$.)

2 Voltage gated channels

The basis for the action potential is the voltage gated ion channel. That is the conductance of the channel is dependent on the membrane potential at the time. This throws a monkey wrench into the equilibrium potential since the conductances are actually nonlinear function of the voltage. As in Kandel and Schwartz,

Channeling with Bard

Comp Neuroscience

January 29, 1998

1 Channels – their effects

Ionic channels appear throughout membranes in neurons and are responsible for most of the interesting dynamic behavior. They play a fundamental role in the properties and connections of neurons and neural nets. So far, we have viewed the membrane as a passive cable with inputs and inhomogeneities. However, as we have seen, cables can transmit information only in a very analog fashion and for long distances would require an enormous diameter. (Homework: Given $R_m = 100000\Omega cm^2$ and $R_a = 100\Omega cm$ what diameter would you need to get a length constant of a meter? – This is less than the distance traveled to the spinal cord from nerves in the foot.)

This problem can be resolved if there is a means to keep the potential of the cable localized and high. This is exactly the problem that action potentials solve. In a real nerve cell there are many species of ions, calcium, potassium, sodium, chloride, magnesium, to name a few of the most common. The basis for the resting membrane potential is the balance of these ions in the cell and outside of the cell. There are basically two forces at work in absence of ionically selective channels: (i) passive diffusion in which case high concentrations tend to move toward low concentrations and (ii) electric forces which attempt to balance the charges on either side of the membrane.

Hodgkin and Huxley won the Nobel prize for their elegant experimental and theoretical work on the nature of the voltage gated channels in the squid axon. This theory is the basis for all subsequent models of ionic channels in nerve and other membranes. Some of the details may differ, but the basic ideas are the same.

Channels facilitate the passive flow of ions across the membrane. When they are gated by other forces such as calcium or voltage, they can also provide great computational properties to the neuron. Non-gated channels are responsible for the membrane potential. Recall that the equilibrium potential of an ion is given by:

$$E = 2.303 \frac{RT}{ZF} \log \frac{[C]_o}{[C]_i}$$

where C is the concentration, and at $25^\circ C$ we have $2.303RT/ZF = 60 \text{ mV}$ when $Z = +1$. Thus, since there are 20 mMoles of potassium inside and 400 outside $E_K = -78 \text{ mV}$. $E_{Na} = 55 \text{ mV}$ and $E_{Cl} = -60 \text{ mV}$. Recall that the membrane potential is found from the Goldman equation:

$$V_m = \frac{RT}{F} \ln \frac{\sum P_j [C_j]_o}{\sum P_j [C_j]_i}$$

where P_j are the permeabilities of the ions. At rest

$$P_K : P_{Na} : P_{Cl} = 1 : .04 : .45$$

during the peak of the action potential

$$P_K : P_{Na} : P_{Cl} = 1 : 20 : .45$$

This is really the correct way to discern the membrane potential, however, in modeling, we will make a much simpler *equivalent circuit*. We will treat each ion channel as a conductor and a battery. Note that